



TEKNOTHERM

MARINE



RSW - LIQUID CHILLER VK

Type VK

Flooded Shell & Tube design for seawater and brackish water. Designed for halocarbons.

Shell

Made of seamless steeltube in quality St. 35 according to Det Norske Veritas requirements.

End plates

These are made of solid, stainless, acid resistant steel. The plates are welded to the shell. The holes for the tubes are exactly made, with grooves to assure a safety tightening as tubes are rolled in.

The tubes for halocarbons are made of aluminium-brass in the well known alloy for seawater, 76% copper, 2% aluminium and 22% zinc. This alloy has proved to have extremely high resistance against corrosion from seawater and brackish water.

The tubes are of "low fin" construction with external fins made from the tube itself. Outside surface then increases considerably, resulting in a high efficiency compact cooler. The tubes are rolled into the endplates, and are replaceable.

Supporting plates

For support of the tubes and to avoid vibration and noise, supporting plates are mounted in the chiller.

End covers

The end covers are in standard execution of cast iron or galvanized steel, for flange connections. For protection against corrosion, end covers are equipped with corrosion plugs.

Suction vessel

Suction vessel of ample size constructed with inside baffles to give extremely good separation of refrigerant drops and oil, which is of great importance onboard ships.

Standard equipment

Oil separator, refrigerant injection valve, liquid level glass, safety valve, purge valve, low-temp. safety thermostat. Standard chiller delivered with separate HP pilot floatvalve. Alternatively built-on LP floatvalve with level safety float switch. Ammonia models will have oil drain.

RSW - LIQUID CHILLER VK

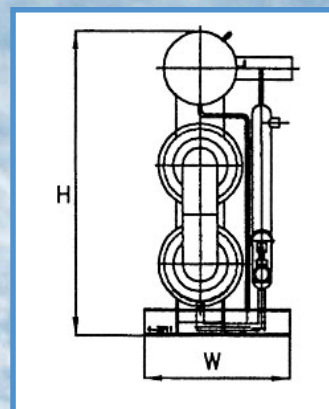
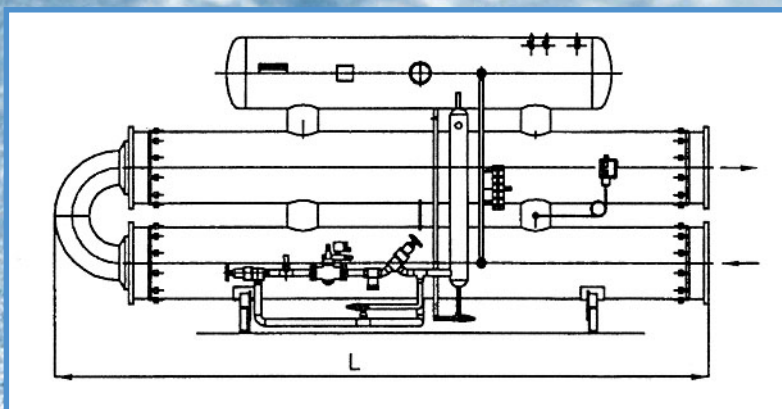

Type	Nom. cap. kW LMTD = 4,5°C	Water side			Refr. side			Unit dimensions			Weight kg	
		m ³ /h	dP M.W. G	D.N	Connections		appr. charge ltr.	L mm	W mm	H mm	Net	Oper- ating
					Suction	Liquid						
VK2 x 22/3,5 2F212	875	500	5,00	250	169,3	76,1	595	4520	1000	2070	4400	5150
VK2 x 22/3 2F212	750	500	4,55	250	169,3	76,1	510	4000	1000	2070	3750	4410
VK2 x 18/3,5 2F142	585	320	4,60	200	139,7	60,3	395	4230	900	1841	2600	3120
VK2 x 18/3 2F142	500 455	320 255	4,30 2,70	200	139,7	60,3	340	3740	900	1841	2200	2640
VK2 x 18/2 2F142	330 300	320 255	3,50 2,20	200	139,7	60,3	225	2730	900	1841	1560	1850
VK2 x 16/3 2F100	350 315	225 180	4,75 3,00	150 or 2x100	114,3	42,4	295	3565	900	1580	1670	2050
VK2 x 16/2 2F100	235 210	225 180	3,95 2,50	150 or 2x100	88,9	42,4	195	2575	900	1580	1160	1420
VK1 x 16/3 F100	175 160	115 90	5,35 3,30	100	88,9	42,4	105	3200	900	1200	860	1000
VK1 x 16/2 F100	120 105	115 90	4,50 2,75	100	88,9	42,4	70	2240	900	1200	680	770
VK2 x 14/2 2F80	190 170	180 145	4,50 2,95	125 or 2x80	88,9	42,4	145	2575	800	1520	970	1160
VK x 14/2 F80	95 65	90 55	6,00 2,25	80	88,9	33,7	55	2200	800	1100	670	740

Note:

- * Capacities are based on R-22/R-507
- * Stated capacities are nominal
- * Other capacities on request
- * Type VK2 x 22" is standardized with galv. Steel waterheads
- * HC tubes

Optionals:

- * Ammonia models
- * Other refrigerants on request
- * Low temp. brine models
- * Classification certificates
- * Small series, 10 - 100 kW

Exmpl.of conversion:

- 1 mm = 0,04"
- 1 m³/h = 0,59 ft³/min
- 1 kg = 2,205 lb
- 1 kW = 860 kcal/h
- = 0,285 tons of refr.

We reserve the rights to change specification without notice.

Rev. 01/2012

Head office - Halden

P.O. Box 87, N-1751 Halden, Norway

Phone: +47 69 19 09 00 - Fax: +47 69 19 09 01

www.teknotherm.com



TEKNOTHERM
MARINE